



## PSEN cs2.2n

- ▶ PSEN sensor technology

**PILZ**  
THE SPIRIT OF SAFETY

This document is a translation of the original document.

All rights to this documentation are reserved by Pilz GmbH & Co. KG. Copies may be made for internal purposes. Suggestions and comments for improving this documentation will be gratefully received.

Source code from third-party manufacturers or open source software has been used for some components. The relevant licence information is available on the Internet on the Pilz homepage.

Pilz®, PIT®, PMI®, PNOZ®, Primo®, PSEN®, PSS®, PVIS®, SafetyBUS p®, SafetyEYE®, SafetyNET p®, the spirit of safety® are registered and protected trademarks of Pilz GmbH & Co. KG in some countries.



SD means Secure Digital

<b>Introduction</b>	<b>4</b>
Validity of documentation	4
Using the documentation	4
Definition of symbols	4
<b>Safety</b>	<b>5</b>
Intended use	5
Safety regulations	5
Safety assessment	5
Use of qualified personnel	6
Warranty and liability	6
Disposal	6
For your safety	7
<b>Unit features</b>	<b>7</b>
<b>Function description</b>	<b>7</b>
Block diagram	8
Operating distances	8
Lateral and vertical offset	9
<b>Wiring</b>	<b>9</b>
Pin assignment, connector and cable	10
<b>Connection to evaluation devices</b>	<b>10</b>
<b>Teaching in the actuator</b>	<b>12</b>
<b>Installation</b>	<b>13</b>
<b>Adjustment</b>	<b>14</b>
<b>Operation</b>	<b>14</b>
Error display through flashing codes	15
<b>Dimensions in mm</b>	<b>17</b>
<b>Technical details</b>	<b>17</b>
Safety characteristic data	20
<b>Supplementary data</b>	<b>20</b>
Radio approval	20
<b>Order reference</b>	<b>21</b>
System	21
Accessories	21
<b>EC declaration of conformity</b>	<b>22</b>

## Introduction

### Validity of documentation

This documentation is valid for the product PSEN cs2.2n. It is valid until new documentation is published.

This operating manual explains the function and operation, describes the installation and provides guidelines on how to connect the product.

### Using the documentation

This document is intended for instruction. Only install and commission the product if you have read and understood this document. The document should be retained for future reference.

### Definition of symbols

Information that is particularly important is identified as follows:



#### **DANGER!**

This warning must be heeded! It warns of a hazardous situation that poses an immediate threat of serious injury and death and indicates preventive measures that can be taken.



#### **WARNING!**

This warning must be heeded! It warns of a hazardous situation that could lead to serious injury and death and indicates preventive measures that can be taken.



#### **CAUTION!**

This refers to a hazard that can lead to a less serious or minor injury plus material damage, and also provides information on preventive measures that can be taken.



#### **NOTICE**

This describes a situation in which the product or devices could be damaged and also provides information on preventive measures that can be taken. It also highlights areas within the text that are of particular importance.

**INFORMATION**

This gives advice on applications and provides information on special features.

**Safety****Intended use**

Safety function of safety switch:

- ▶ 2 safety outputs, each of which supply a high signal when the actuator is in the safety switch's response range.

The safety switch meets the requirements in accordance with:

- ▶ EN 60947-5-3 with the actuator PSEN cs2.1 : PDDDB
- ▶ EN 62061: SIL CL 3
- ▶ EN ISO 13849-1: PL e (Cat. 4)
- ▶ EN ISO 14119: Coding level High, Type4

The safety switch may only be used with the corresponding actuator PSEN cs2.1.

The safety level PL e (Cat. 4 )/SIL CL 3 is only achieved if

- ▶ the safety outputs use 2-channel processing.

The following is deemed improper use in particular:

- ▶ Any component, technical or electrical modification to the product
- ▶ Use of the product outside the areas described in this manual
- ▶ Use of the product outside the technical details (see [Technical details](#) [ 17]).

**NOTICE****EMC-compliant electrical installation**

The product is designed for use in an industrial environment. The product may cause interference if installed in other environments. If installed in other environments, measures should be taken to comply with the applicable standards and directives for the respective installation site with regard to interference.

**Safety regulations****Safety assessment**

Before using a unit it is necessary to perform a safety assessment in accordance with the Machinery Directive.

Functional safety is guaranteed for the product as a single component. However, this does not guarantee the functional safety of the overall plant/machine. In order to achieve the required safety level for the overall plant/machine, define the safety requirements for the plant/machine and then define how these must be implemented from a technical and organisational standpoint.

### **Use of qualified personnel**

The products may only be assembled, installed, programmed, commissioned, operated, maintained and decommissioned by competent persons.

A competent person is a qualified and knowledgeable person who, because of their training, experience and current professional activity, has the specialist knowledge required. To be able to inspect, assess and operate devices, systems and machines, the person has to be informed of the state of the art and the applicable national, European and international laws, directives and standards.

It is the company's responsibility only to employ personnel who

- ▶ Are familiar with the basic regulations concerning health and safety / accident prevention,
- ▶ Have read and understood the information provided in this description under "Safety"
- ▶ Have a good knowledge of the generic and specialist standards applicable to the specific application.

### **Warranty and liability**

All claims to warranty and liability will be rendered invalid if

- ▶ The product was used contrary to the purpose for which it is intended
- ▶ Damage can be attributed to not having followed the guidelines in the manual
- ▶ Operating personnel are not suitably qualified
- ▶ Any type of modification has been made (e.g. exchanging components on the PCB boards, soldering work etc.).

### **Disposal**

- ▶ In safety-related applications, please comply with the mission time  $T_M$  in the safety-related characteristic data.
- ▶ When decommissioning, please comply with local regulations regarding the disposal of electronic devices (e.g. Electrical and Electronic Equipment Act).

**For your safety**



**WARNING!**

Loss of safety function due to manipulation of the interlocking device

Manipulation of the interlocking device may lead to serious injury and death.

- You should prevent any possibility of the interlocking device being manipulated through the use of a spare actuator.
- Keep the substitute actuator in a safe place and protect it from unauthorised access.
- If spare actuators are used, these must be installed as described in [Installation](#) [ 13].
- If the original actuators are replaced with substitute actuators, the original actuators must be destroyed before disposal.

- ▶ Do not remove the connector's protective cap until you are just about to connect the unit. This will prevent potential contamination.

**Unit features**

- ▶ Transponder technology for presence detection
- ▶ Pilz coding type: uniquely coded
- ▶ Dual-channel operation
- ▶ 2 safety outputs
- ▶ LED display for:
  - State of the actuator
  - Supply voltage/fault
- ▶ 4 directions of actuation

**Function description**

The safety outputs may have a high or low signal, depending on the position of the actuator.

In a safe condition there is a low signal at the safety outputs.

State of the outputs:

Actuator in the response range	Safety output 12	Safety output 22
Yes	High	High
No	Low	Low

**Block diagram**

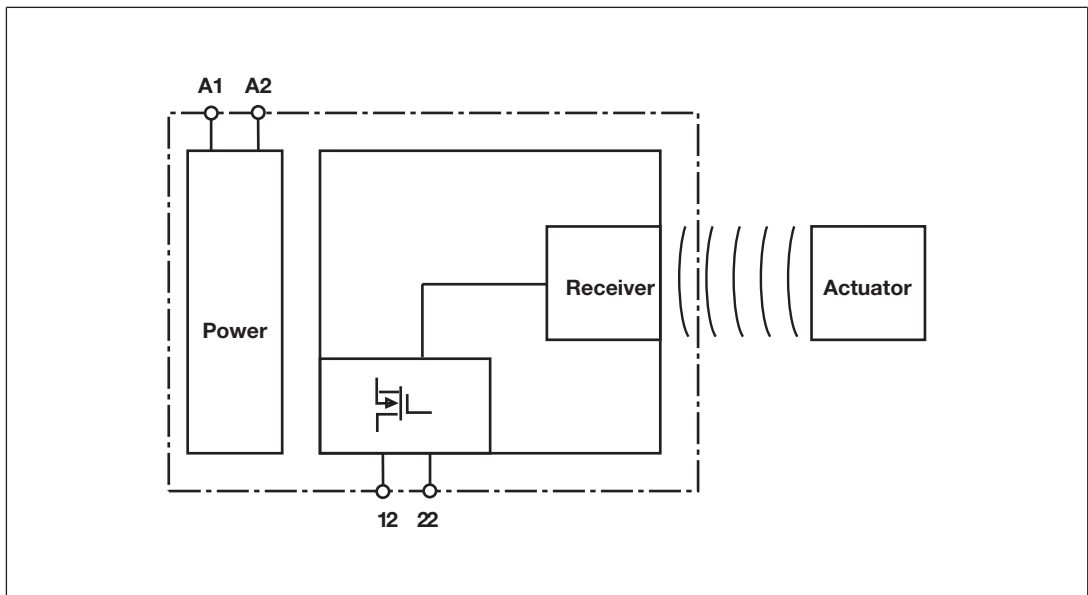

**Operating distances**

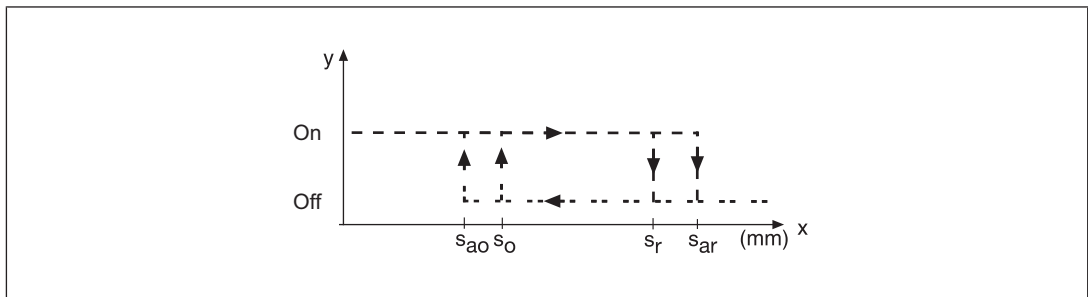

**Legend:**

- ▶  $S_{ao}$  Assured operating distance: 15 mm
- ▶  $S_o$  Typical operating distance: 21 mm
- ▶  $S_r$  Typical release distance: 32 mm
- ▶  $S_{ar}$  Assured release distance: 40 mm

**Lateral and vertical offset**

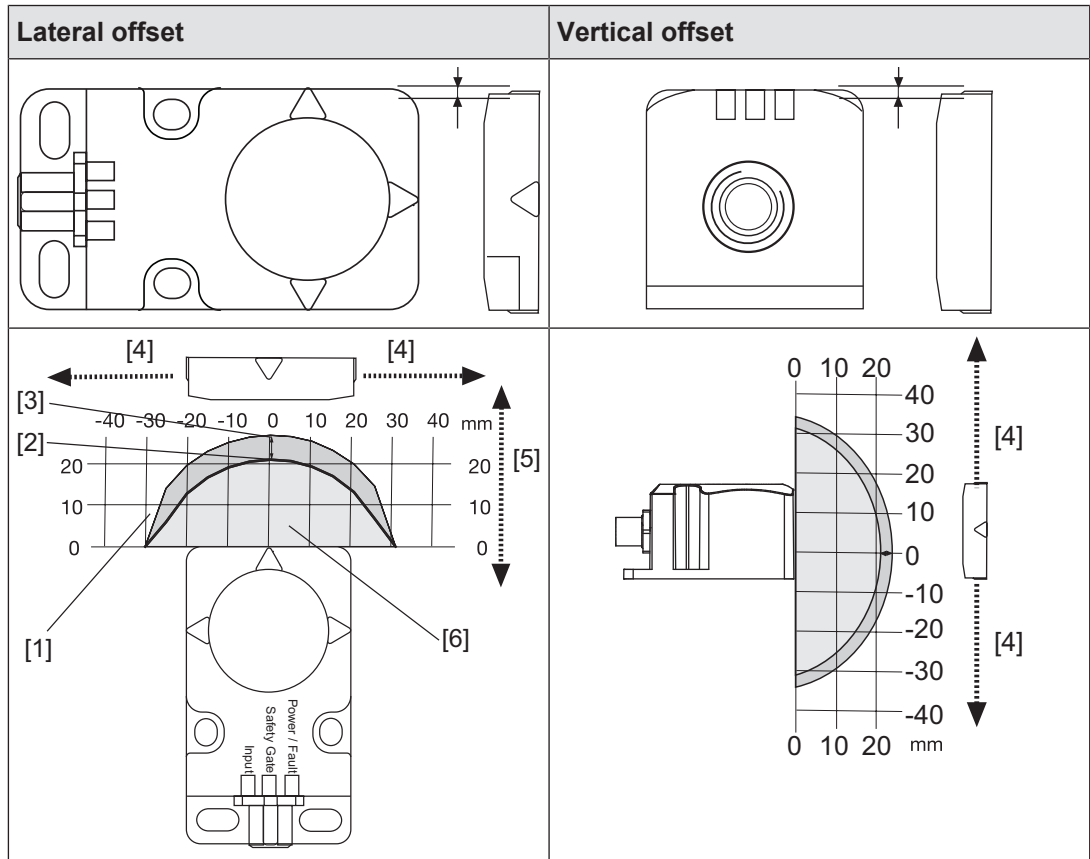

**Legend**

- [1] Hysteresis
- [2] Typical operating distance  $S_o$
- [3] Typical release distance  $S_r$
- [4] Offset in mm
- [5] Operating distance in mm
- [6] Response range

**Wiring**

Please note:

- ▶ Information given in the "Technical details" must be followed.
- ▶ The power supply must meet the regulations for extra low voltages with protective separation (SELV, PELV).
- ▶ The inputs and outputs of the safety switch must have a protective separation to voltages over 60 VDC.

**INFORMATION**

Only use safety relays with a 24 VDC supply voltage. Safety relays with a wide-range power supply or in AC device versions have internal potential isolation and are not suitable as evaluation devices.

- ▶ The supply voltage to the safety switch must be protected with a 2 A to 4 A quick-acting fuse.
- ▶ Ensure the wiring and EMC requirements of IEC 60204-1 are met.

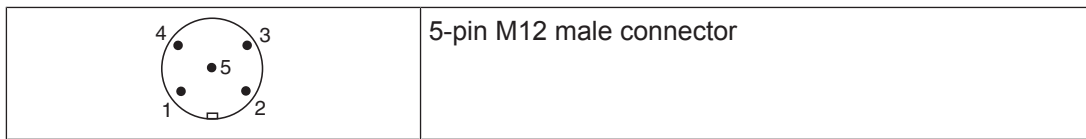
**Pin assignment, connector and cable**

PIN	Pin designation	Function	Wire colour
1	A1	+24 UB	Brown
2	12	Output, channel1	White
3	A2	0 V UB	Blue
4	22	Output, channel2	Black
5	-	Do not connect	Grey

The wire colour also applies for the cable available from Pilz as an accessory.

**Connection to evaluation devices**

Make sure that the selected evaluation device has the following property:

- ▶ OSSD signals are evaluated through 2 channels with feasibility monitoring

Please note:

- ▶ Information given in the [Technical details](#) [ 17] must be followed.

### Connection diagram, single connection

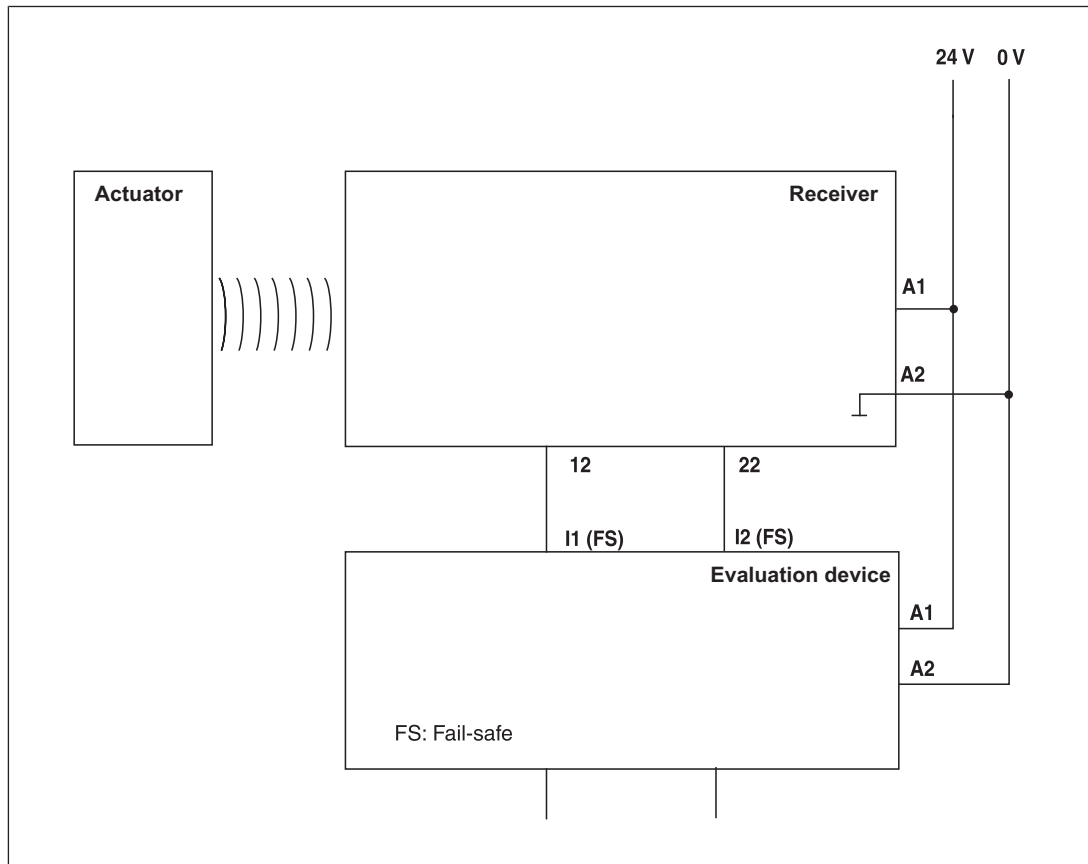

Suitable Pilz evaluation devices are, for example:

- ▶ PNOZelog for safety gate monitoring
- ▶ PNOZpower for safety gate monitoring
- ▶ PNOZsigma for safety gate monitoring
- ▶ PNOZ X for safety gate monitoring
- ▶ PNOZmulti for safety gate monitoring  
Configure the switch in the PNOZmulti Configurator with switch type 3.
- ▶ PSS for safety gate monitoring with standard function block SB064, SB066 or FS\_Safety Gate
- ▶ PSSuniversal PLC for safety gate monitoring with function block FS\_SafetyGate

The correct connection to the respective evaluation device is described in the operating manual for the evaluation device. Make sure that the connection is made in accordance with the specifications in the operating manual for the selected evaluation device.

The connections to two evaluation devices are shown on the following pages, by way of example:

- ▶ PNOZ s3 and
- ▶ PNOZmulti

**PNOZ s3**

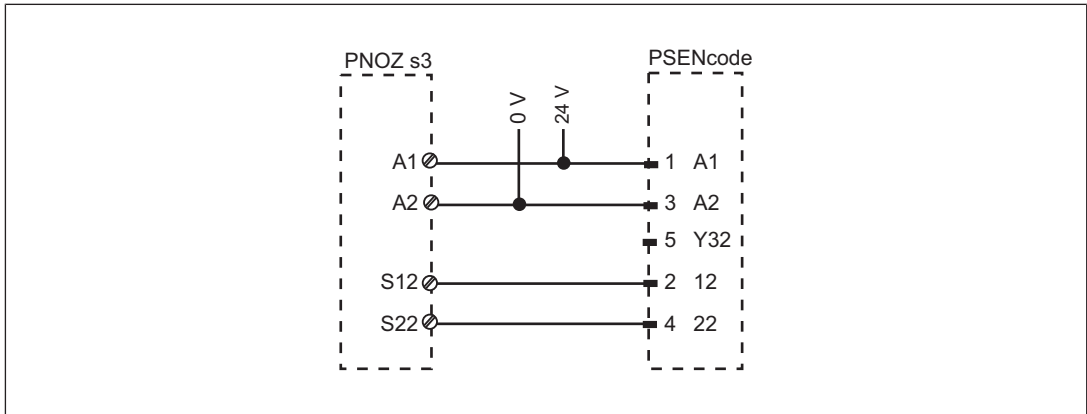

**PNOZmulti**

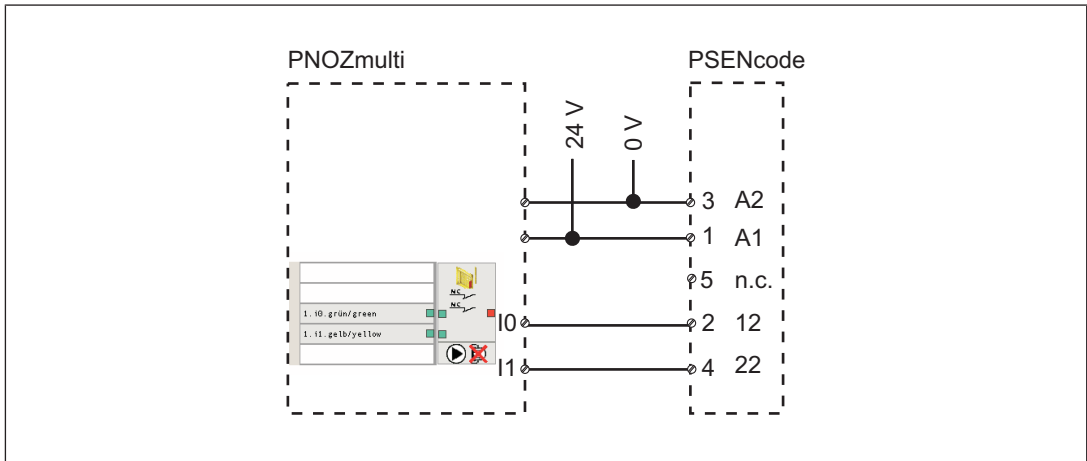

Legend:

I0	Input OSSD
I1	Input OSSD

**Teaching in the actuator**

The **first** actuator PSEN cs2.1 detected by the safety switch is automatically taught in as soon as it is brought into the response range.







**NOTICE**  
No other actuator may be taught in once this actuator has been taught.

## Installation



### CAUTION!

The unit's properties may be affected if installed in an environment containing electrically or magnetically conductive material. Please check the operating distances and the assured release distance.

- ▶ The safety switch and actuator should be installed opposite each other in parallel.
  - Make sure that the actuator is aligned to the marking on the sensor that guarantees the operating distance required by the plant design (see [Operating distances](#) [ 8]).
- ▶ Safety switches and actuators should be permanently secured using M5 safety screws with a flat head (e.g. M5 cheese-head or pan head screws).
- ▶ Protect the actuator from contamination.
- ▶ Torque setting: Please note the information provided under [Technical details](#) [ 17].
- ▶ The distance between two safety switches must be maintained (see [Technical details](#) [ 17]).
- ▶ Make sure that the safety switch and actuator cannot be used as an end stop.
- ▶ Please note the installation measures in accordance with EN ISO 14119 for a safety switch design 4 and with level of coding High
- ▶ For simpler installation, the mounting brackets (see [Order reference for Accessories](#) [ 21]) can be used.
- ▶ If using angled connector plugs, note the defined angle of the cable routing.



### CAUTION!

Possible loss of the safety function by changing the release distance  $S_{ar}$  with non-flush installation

Installing the safety switch non-flush within electrically or magnetically conductive material, the value for the assured release distance  $S_{ar}$  can change.

- Check the assured release distance  $S_{ar}$ .

**Procedure:**

Fig.: Sensing faces on the sensor

1. Drill holes (for M5 screws) in the mounting surface to secure the actuator and sensor (see [Dimensions in mm](#) [📖 17]).
2. Use a screw to fix the sensor to the mounting surface.  
Make sure that the sensor marking that is be used for operation can be operated using the actuator from the right side.
3. Do not fully tighten the second screw on the safety switch.
4. Use a screw to fix the actuator to the mounting surface.  
Make sure that the actuator with the printed side points towards the marking on the sensor.
5. Do not fully tighten the second screw on the actuator.
6. Align the safety switch and tighten the screws.
7. Align the actuator and tighten the screws.

**Adjustment**

- ▶ The stated operating distances (see [Technical details](#) [📖 17]) only apply when the safety switch and actuator are installed facing each other in parallel. Operating distances may deviate if other arrangements are used.
- ▶ Note the maximum permitted lateral and vertical offset (see [Operating distances](#) [📖 8] and [Lateral and vertical offset](#) [📖 9]).

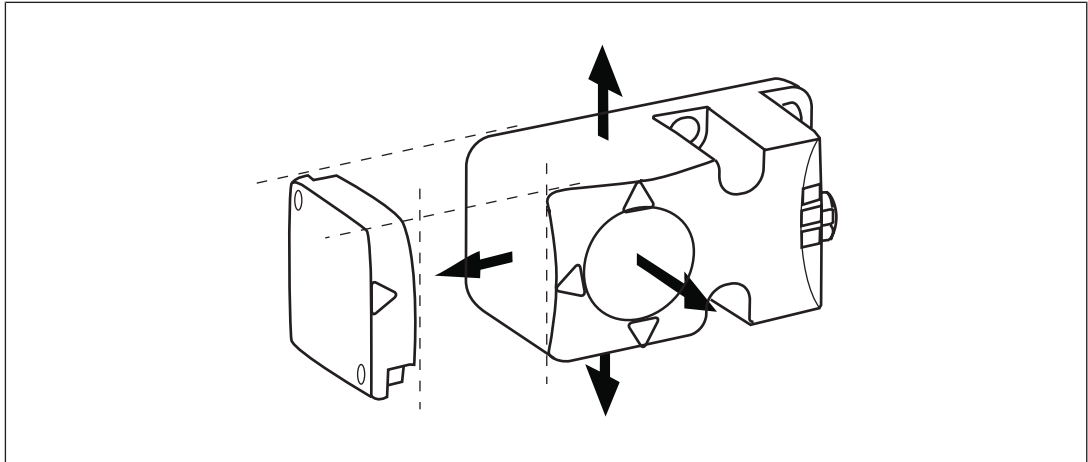
**Operation****NOTICE**

The safety function should be checked after initial commissioning and each time the plant/machine is changed. The safety functions may only be checked by qualified personnel.

Check the function of the safety switch before commissioning.

**Status indicators:**

- ▶ "POWER/Fault" LED lights up green: The unit is ready for operation
- ▶ "Safety Gate" LED lights up yellow: Actuator is within the response range
- ▶ "Input" LED lights up yellow: Device is error-free

**Fault indicator:**

- ▶ "POWER/Fault" LED lights up red: Error message.  
Flashing codes for fault diagnostics are output to the "Safety Gate" and "Input" LEDs (see Error display through flashing codes).  
Remedy: Rectify fault and interrupt power supply.

**Error display through flashing codes**

The "Safety Gate" and "Input" LEDs send flash signals; an error code can be established from the number and sequence. The "Power/Fault" LED illuminates red.

Each error code is indicated by three short flashes of the "Input" or "Safety Gate" LED. After a longer pause, the LED will then flash at one second intervals. The number of LED flashes corresponds to a digit in the error code. The error code can consist of up to 3 digits. The digits are separated by a longer period without flashing. The entire sequence is constantly repeated.

Number of flashes	1 2 3 4 5 6 7 8 9 10 11 12 13 14 15 16
Decimal error code	1 2 3 4 5 6 7 8 9 10 11 12 13 14 15 0

**Example:**

Error code 1,4,1:

Flash frequency of the "Safety Gate" or "Input" LED

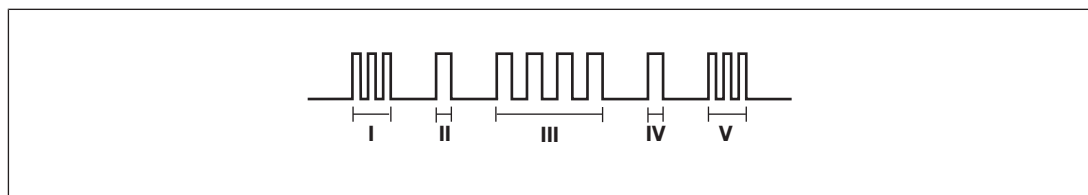

**Meaning of flash frequency:**

	Flash frequency	Meaning
I	3 times, short	Code for error message
II	Once, for one second each	Code for 1st digit
III	4 times, for one second each	Code for 2nd digit
IV	Once, for one second each	Code for 3rd digit
V	3 times, short	Code for error message repeated

Table of error codes

<b>Error code</b>			
<b>Decimal</b>	<b>Number of flashes</b>	<b>Description</b>	<b>Remedy</b>
1.4.1	3x short – 1x long – 4x long – 1x long – 3x short	Wiring error	Rectify wiring error
1.12	3x short – 1x long – 12x long – 3x short	Wiring error	Rectify wiring error
1.13	3x short – 1x long – 12x long – 3x short	Wiring error	Rectify wiring error
14	3x short – 14x long – 3x short	Wiring error	Rectify wiring error
15	3x short – 15x long – 3x short	Wiring error	Rectify wiring error

Other flashing codes signal an internal error. Remedy: Change device.

## Dimensions in mm

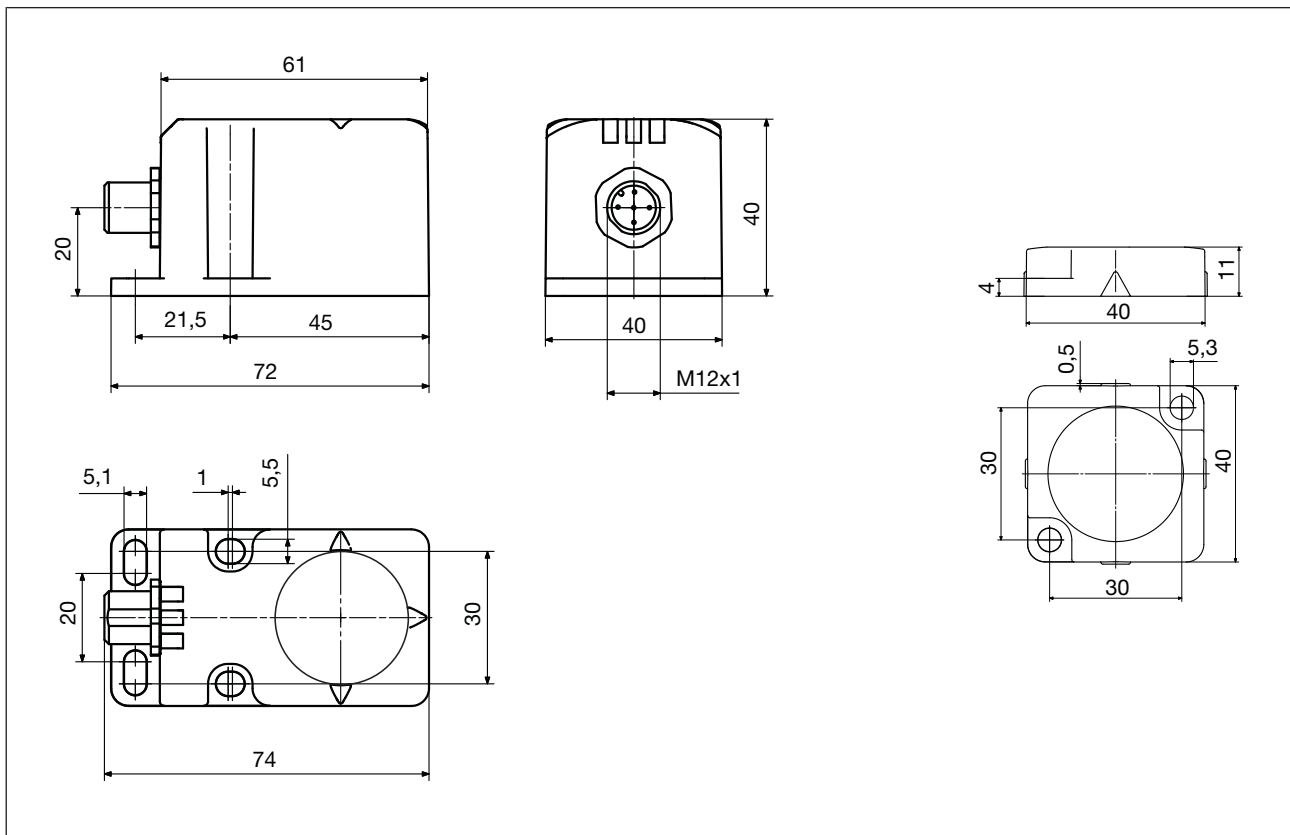

## Technical details

General	
Approvals	CE, EAC (Eurasian), FCC, IC, TÜV, cULus Listed
Sensor's mode of operation	Transponder
Coding level in accordance with EN ISO 14119	High
Design in accordance with EN ISO 14119	4
Classification in accordance with EN 60947-5-3	PDDb
Pilz coding type	uniquely coded
Transponder	
Frequency band	122 kHz - 128 kHz
Max. transmitter output	7 dBm
Electrical data	
Supply voltage	
Voltage	24 V
Kind	DC
Voltage tolerance	-20 %/+20 %
Output of external power supply (DC)	2 W
Max. inrush current at UB	0,12 A
Max. switching frequency	3 Hz

<b>Electrical data</b>	
Max. cable capacitance at the safety outputs	
No-load, PNOZ with relay contacts	<b>40 nF</b>
PNOZmulti, PNOZelog, PSS	<b>70 nF</b>
No-load current	<b>50 mA</b>
<b>Semiconductor outputs</b>	
OSSD safety outputs	<b>2</b>
Switching current per output	<b>500 mA</b>
Breaking capacity per output	<b>12 W</b>
Potential isolation from system voltage	<b>No</b>
Short circuit-proof	<b>yes</b>
Residual current at outputs	<b>10 µA</b>
Voltage drop at OSSDs	<b>3,5 V</b>
Lowest operating current	<b>0 mA</b>
Utilisation category in accordance with EN 60947-1	<b>DC-12</b>
<b>Times</b>	
Test pulse duration, safety outputs	<b>450 µs</b>
Switch-on delay	
after UB is applied	<b>1 s</b>
Actuator typ.	<b>80 ms</b>
Actuator max.	<b>150 ms</b>
Delay-on de-energisation	
Actuator typ.	<b>40 ms</b>
Actuator max.	<b>260 ms</b>
Risk time in accordance with EN 60947-5-3	<b>260 ms</b>
Supply interruption before de-energisation	<b>20 ms</b>
Simultaneity, channel 1 and 2 max.	<b>∞</b>
<b>Environmental data</b>	
Ambient temperature	
In accordance with the standard	<b>EN 60068-2-14</b>
Temperature range	<b>-25 - 70 °C</b>
Storage temperature	
In accordance with the standard	<b>EN 60068-2-1/-2</b>
Climatic suitability	
In accordance with the standard	<b>EN 60068-2-78</b>
Humidity	<b>93 % r. h. at 40 °C</b>
EMC	<b>EN 60947-5-3</b>
Vibration	
In accordance with the standard	<b>EN 60947-5-2</b>
Frequency	<b>10 - 55 Hz</b>
Amplitude	<b>1 mm</b>
Shock stress	
In accordance with the standard	<b>EN 60947-5-2</b>
Acceleration	<b>30g</b>
Duration	<b>11 ms</b>

<b>Environmental data</b>	
Airgap creepage	
Overvoltage category	<b>III</b>
Pollution degree	<b>3</b>
Rated insulation voltage	<b>75 V</b>
Rated impulse withstand voltage	<b>0,8 kV</b>
Protection type	
Housing	<b>IP67</b>
<b>Mechanical data</b>	
Actuator 1	<b>PSEN cs2.1</b>
Operating distances	
Assured operating distance Sao	<b>15 mm</b>
Typical operating distance So	<b>21 mm</b>
Assured release distance Sar	<b>40 mm</b>
Typical release distance Sr	<b>32 mm</b>
Repetition accuracy switching distances	<b>10 %</b>
Change of operating distance with temperature changes	<b>+0,01mm/°C</b>
Typ. Hysteresis	<b>3 mm</b>
Min. distance between safety switches	<b>400 mm</b>
Sensor flush installation in accordance with EN 60947-5-2	<b>Yes, follow installation guidelines</b>
Connection type	<b>M12, 5-pin male connector</b>
Material	
Top	<b>PBT</b>
Max. torque setting for fixing screws	<b>1 Nm</b>
Dimensions	
Height	<b>75 mm</b>
Width	<b>40 mm</b>
Depth	<b>40 mm</b>
Actuator dimensions	
Height	<b>11 mm</b>
Width	<b>40 mm</b>
Depth	<b>40 mm</b>
Weight of safety switch	<b>130 g</b>
Weight of actuator	<b>20 g</b>
Weight	<b>150 g</b>

Where standards are undated, the 2016-10 latest editions shall apply.

**Safety characteristic data**



**NOTICE**  
 You must comply with the safety-related characteristic data in order to achieve the required safety level for your plant/machine.

Operating Mode	EN ISO 13849-1: 2015 PL	EN ISO 13849-1: 2015 Category	EN 62061 SIL CL	EN 62061 PFH <sub>D</sub> [1/h]	IEC 61511 SIL	IEC 61511 PFD	EN ISO 13849-1: 2015 T <sub>M</sub> [year]
2-ch. OSSD	PL e	Cat. 4	SIL CL 3	4,10E-09	–	1,10E-04	20

All the units used within a safety function must be considered when calculating the safety characteristic data.



**INFORMATION**  
 A safety function's SIL/PL values are **not** identical to the SIL/PL values of the units that are used and may be different. We recommend that you use the PAscal software tool to calculate the safety function's SIL/PL values.

**Supplementary data**

**Radio approval**

*USA/Canada*

**FC** FCC ID: VT8-PSENCs1  
 IC: 7482A-PSENCs1

FCC/IC-Requirements:  
 This product complies with Part 15 of the FCC Rules and with Industry Canada licence-exempt RSS standards. Operation is subject to the following two conditions:  
 1) this product may not cause harmful interference, and  
 2) this product must accept any interference received, including interference that may cause undesired operation.

Changes or modifications made to this product not expressly approved by Pilz may void the FCC authorization to operate this equipment.

NOTE: This equipment has been tested and found to comply with the limits for a Class A digital device, pursuant to Part 15 of the FCC Rules. These limits are designed to provide reasonable protection against harmful interference when the equipment is operated in a commercial environment. This equipment generates, uses, and can radiate radio frequency energy and, if not installed and used in accordance with the instruction manual, may cause harmful interference to radio communications. Operation of this equipment in a residential area is likely to cause harmful interference in which case the user will be required to correct the interference at his own expense.

Le présent produit est conforme aux CNR d'Industrie Canada applicables aux appareils radio exempts de licence. L'exploitation est autorisée aux deux conditions suivantes:  
 (1) le produit ne doit pas produire de brouillage, et  
 (2) l'utilisateur de le produit doit accepter tout brouillage radioélectrique subi, même si le brouillage est susceptible d'en compromettre le fonctionnement.

## Order reference

### System

Product type	Features	Connection type	Order no.
PSEN cs2.2n / PSEN cs2.1	Safety gate system, uniquely coded	5-pin M12 connector	540 203
PSEN cs2.2n (switch)	Safety switch, uniquely coded	5-pin M12 connector	540 253
PSEN cs2.1	Actuator, coded		540 180

### Accessories

#### Installation materials

Product type	Features	Order no.
PSEN bracket	Mounting bracket	532 110
PSEN mag/cs bracket straight	Mounting aid	532 111
PSEN screw M5x10 10pcs	Safety screws made from stainless steel with one-way slot	540 311
PSEN screw M5x20 10pcs	Safety screws made from stainless steel with one-way slot	540 312
PSEN cs1/2 bracket cable fix	Mechanical protection against defeat, protecting against unauthorised cable disconnection or damage for safety switches PSENcode cs1/2, PSENcode cs5/6 M12, PSENslock	532 112

### Cable

Product type	Connection 1	Connection 2	Length	Order No.
PSS67/PDP67 cable M12-5sf	Straight, M12, 5-pin, socket	Straight, M12, 5-pin, connector	3 m	380 208
			5 m	380 209
			10 m	380 210
			20 m	380 220
			30 m	380 211
PSS67/PDP67 cable M12-5af	Angled, M12, 5-pin, socket	Angled, M12, 5-pin, connector	3 m	380 212
			5 m	380 213
			10 m	380 214
			30 m	380 215
PSEN cable M12-5sf	Straight, M12, 5-pin, socket	Open cable	3 m	630 310
			5 m	630 311
			10 m	630 312
			20 m	630 298
			30 m	630 297

Product type	Connection 1	Connection 2	Length	Order No.
PSEN cable M12-5af	Angled, M12, 5-pin, socket	Open cable	3 m	630 347
			5 m	630 348
			10 m	630 349
			30 m	630 350
PDP67 F 8DI ION	Decentralised input module IP67 for PNOZmulti			773 600

### EC declaration of conformity

This product/these products meet the requirements of the directive 2006/42/EC for machinery of the European Parliament and of the Council. The complete EC Declaration of Conformity is available on the Internet at [www.pilz.com/downloads](http://www.pilz.com/downloads).

Representative: Norbert Fröhlich, Pilz GmbH & Co. KG, Felix-Wankel-Str. 2, 73760 Ostfildern, Germany